

MASTER FLOW® - water level valve

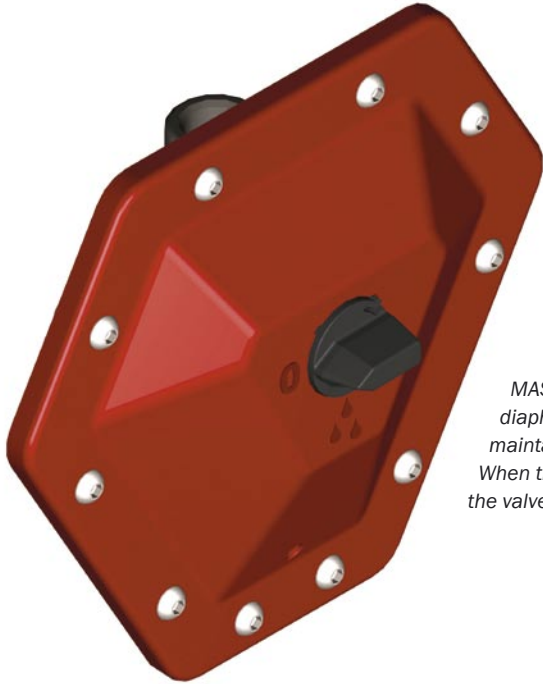

MASTER FLOW® water level valve is a diaphragm-operated valve system, which maintains a constant water level in a trough. When the water level has been reached, the valve closes.

examples

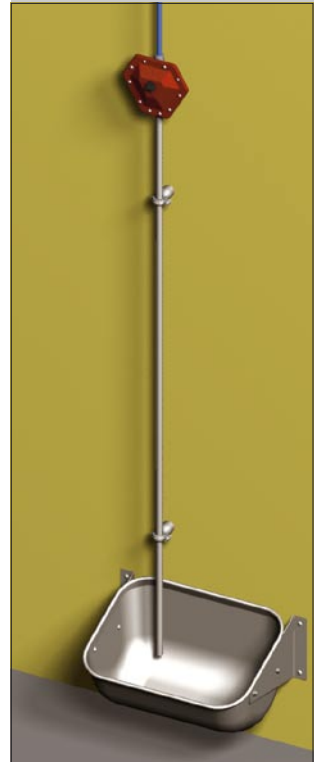

Reliable water supply

- Maintains a constant water level

Contributes to a good state of health

- Ensures a water surface that increases the pigs' desire to drink

Easy to use

- Functional turn on/off button

Flexible mounting

Allows connection of both horizontal and vertical water pipes

Low risk of bacteria

- Works perfectly without a hose, which easily accumulate feed remains

INSTALLATION

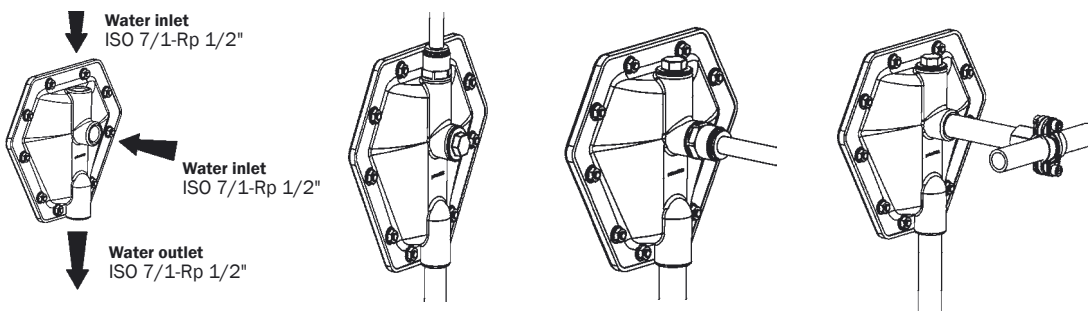

FACTS

Minimum length of water pipe	80 cm
Maximum length of water pipe	200 cm
Pcs. per box 55 x 45 x 55 cm	50 pcs.

MASTER FLOW®

No.	Description
93.469	MASTER FLOW®
94.046	½" stainless steel water pipe with thread, 100 cm
94.047	½" stainless steel water pipe with thread, 150 cm
94.048	½" stainless steel water pipe with thread, 200 cm

